

# Genie® Z®-40/23N & Z-40/23N RJ

## Specifications

Models	Z-40/23N		Z-40/23N RJ	
Measurements	US	Metric	US	Metric
Working height max.(1)	46 ft 5 in	14.32 m	46 ft 5 in	14.32 m
Platform height max.	40 ft 5 in	12.32 m	40 ft 5 in	12.32 m
Horizontal reach max.	22 ft 8 in	6.91 m	22 ft 8 in	6.91 m
Up and over clearance max.	21 ft 3 in	6.48 m	21 ft 3 in	6.48 m
<b>A</b> Platform length	2 ft 6 in	0.76 m	2 ft 6 in	0.76 m
<b>B</b> Platform width	4 ft 8 in	1.42 m	3 ft 10 in	1.17 m
<b>C</b> Height - stowed	6 ft 6 in	1.98 m	6 ft 6 in	1.98 m
<b>D</b> Length - stowed	21 ft 5 in	6.53 m	21 ft 5 in	6.53 m
<b>E</b> Width	4 ft 11 in	1.50 m	4 ft 11 in	1.50 m
<b>F</b> Wheelbase	6 ft 5 in	1.96 m	6 ft 5 in	1.96 m
<b>G</b> Ground clearance - center	9.5 in	0.24 m	9.5 in	0.24 m

### Productivity

Lift capacity max. - unrestricted	500 lb	227 kg	500 lb	227 kg
Platform rotation	180°		180°	
Jib length	4 ft	1.22 m	4 ft	1.22 m
Vertical jib rotation	128°		128°	
Horizontal jib rotation	—		180°	
Turntable rotation	355°		355°	
Turntable tailswing	5 in	0.13 m	5 in	0.13 m
Drive speed - stowed <sup>(2)</sup>	4.5 mph	7.2 km/h	4.5 mph	7.2 km/h
Drive speed - raised	0.68 mph	1.1 km/h	0.68 mph	1.1 km/h
Gradeability - stowed <sup>(2)</sup>	30%		30%	
Tilt sensor activation (front to back/side to side)	2.5° - 4.5° / 4.5°		2.5° - 4.5° / 4.5°	
Turning radius - inside/outside	2ft 11 in/10ft 6 in	0.87 m/3.20 m	2ft 11 in/10ft 6 in	0.87 m/3.20 m
Tires (solid, non-marking)	22×7× 17.75 in	0.56×0.18× 0.45 m	22×7× 17.75 in	0.56×0.18× 0.45 m

### Power

Power	48V DC (8×6V 350Ah)		48V DC (8×6V 350Ah)	
Drive system	48V 3-Phase AC		48V 3-Phase AC	
Auxiliary power unit	24V DC		24V DC	
Hydraulic tank capacity	8 gal	30.3 L	8 gal	30.3 L

### Weight(3) and Floor Loading<sup>(4)</sup>

Weight	15,230 lb	6,908 kg	15,300 lb	6,940 kg
Tire contact pressure	200 psi	1379 kPa	200 psi	1379 kPa
Occupied floor pressure (tires)	372 psf	17.8 kPa	372 psf	17.8 kPa

### Sound and Vibration Levels

Sound Pressure level (ground workstation)	< 70 dBA		< 70 dBA	
Sound Pressure level (platform workstation)	< 70 dBA		< 70 dBA	
Vibrations	8 ft 2 in/s <sup>2</sup>	2.5 m/s <sup>2</sup>	8 ft 2 in/s <sup>2</sup>	2.5 m/s <sup>2</sup>

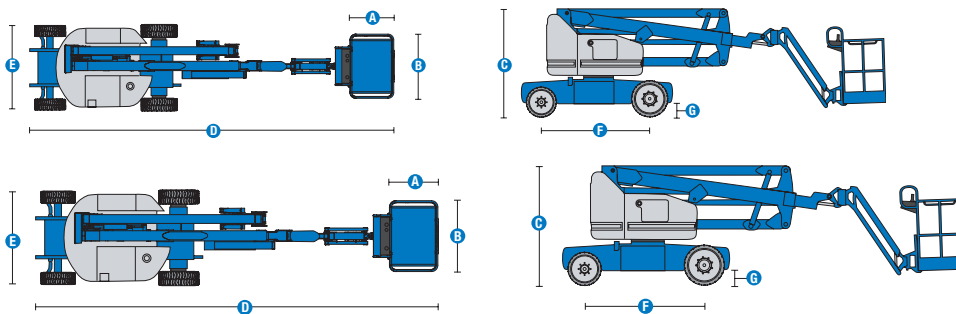

(1) The metric equivalent of working height adds 2m to platform height. The imperial equivalent adds 6ft to platform height.  
 (2) Gradeability applies to driving on slopes and may vary depending on options and machine configurations. See operator's manual for details regarding slope ratings.  
 (3) Weight refers to standard configuration and may vary depending on options and/or country standards.  
 (4) Floor loading information is approximate and may vary depending on options and machine configurations. It should be used only with adequate safety factors.

### Range of motion Z-40/23N

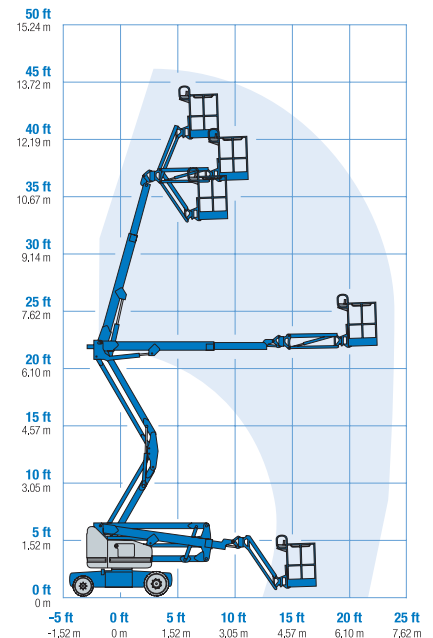

### Range of motion Z-40/23 N RJ

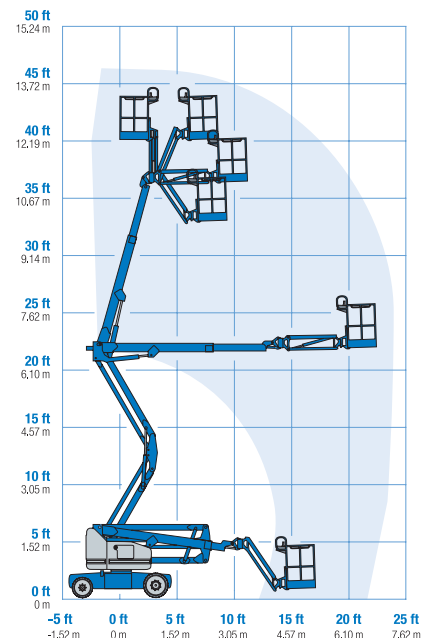

### Jib range of motion Z-40/23N RJ

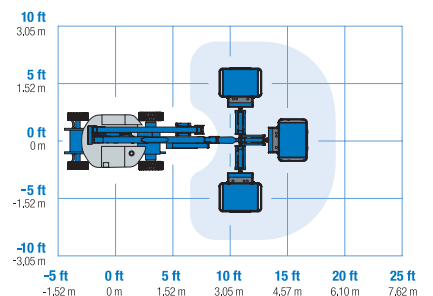

# Genie® Z®-40/23N & Z-40/23N RJ

## SKU: Standard Model

- **Z40N0001AE0002:** Z-40/23N with Jib, DC Power, 2WD
- **Z40NRJ01AE0003:** Z-40/23N RJ, DC Power, 2WD
- **Z40NRJ01AF0004:** Z-40/23N RJ, DC Power, Swing gate, 2WD

\* Build to Order

Option availability		S	S+	BtO
Power	Standard FLA flooded lead acid battery	✓	✓	✓
	AGM Maintenance-free batteries		○	○
	Power Inverter, 800W, 120V AC, 60Hz		○	○
	Low voltage interrupt (LVI) with battery charge indicator (BCI)	✓	✓	✓
Platform	3ft 10in/1.17m steel platform	✓	✓	✓
	4ft 8in/1.42m steel platform (not available on RJ)	✓	✓	✓
	Air line to platform			○
	Control box covers		○	○
	Lift Guard Half Mesh panels with swing gate			○
	Light Package: drive and work lights		○	○
	Platform auxiliary top rail			○
	Platform swing gate			○
	AC Power to platform	✓	✓	✓
	Alarm package: flashing beacons, descent, travel and tilt alarms	✓	✓	✓
	Drive enable system	✓	✓	✓
	Horn	✓	✓	✓
	Lift Guard Contact Alarm	✓	✓	✓
	Lift Guard Lanyard Alert			○
	Lift Guard Lanyard Alert Advanced			○
	Platform load sense system	✓	✓	✓
	Proportional controls	✓	✓	✓
Self-leveling platform	✓	✓	✓	
Chassis	Lift Connect Telematics		○	○
	Telematics-ready	✓	✓	✓
	Lift Connect with Access Manager upgrade		○	○
	Biodegradable hydraulic oil			○
	Cold weather hydraulic oil			○
	Fire resistant hydraulic oil			○
	Hostile environment kit			○
	Chassis tilt drive function cut-out	✓	✓	✓
	Chassis tilt lift function cut-out	✓	✓	✓
	Dual parallelogram lift linkage	✓	✓	✓
	Electric brake release	✓	✓	✓
Hour meter	✓	✓	✓	
On-board diagnostic system	✓	✓	✓	
Sealed AC electric drive motors	✓	✓	✓	
Solid, non-marking tires	✓	✓	✓	

- S Standard
- S+ Standard +
- BtO Build to Order
- ✓ Standard Features
- Options



Efficient Electric Drive System



Narrow Access



Rotating Jib

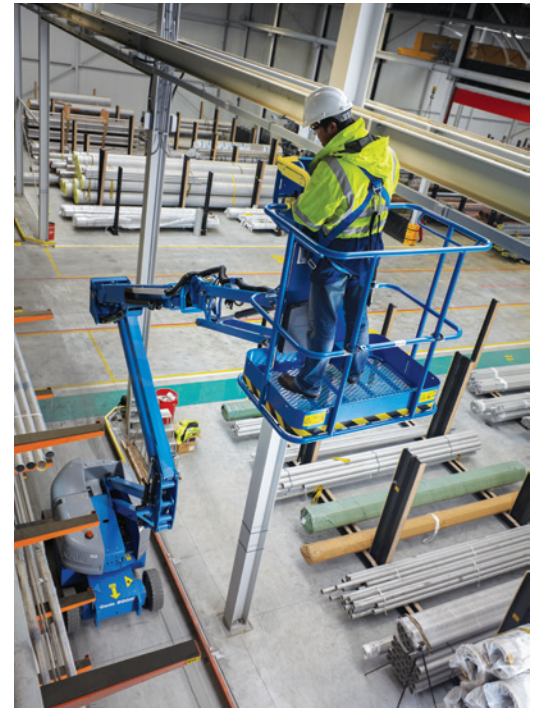

### Genie Genuine Accessories<sup>(1)</sup>

- Lift Tools Productivity Tools
- Lift Connect Telematics
- Tech Pro Link Handheld Device

(1) More accessories available from Genie Genuine Parts.

Product specifications are subject to change without notice or obligation. Photographs and/or drawings herein are for illustrative purposes only. Refer to the appropriate Operator's Manual for instructions on proper equipment use. Failure to follow instructions in the Operator's Manual may result in serious injury or death. The only warranty applicable to our equipment is the standard written warranty applicable to the particular product and sale and we make no other warranty, express or implied. Products and services listed may be trademarks, service marks or trade names of Terex Corporation and/or their subsidiaries in the USA and many other countries. Terex, Genie, Quality By Design, Xtra Capacity, Lift Power, Lift Guard, Lift Tools, Lift Connect and Tech Pro Link are registered trademarks of Terex Corporation or its subsidiaries.